

Product name	Description	Version
LS2003H-G	Standalone GNSS smart antenna module	1.0



1 Introduction

LS2003H-G is a complete standalone GNSS smart antenna module, the module is powered by MediaTek GNSS chip and it can provide you with superior sensitivity and performance even in urban canyon and dense foliage environment.

The module includes embedded chip antenna and GNSS receiver circuits, dedicated designed for tablet PC, MID, PND and smart phone that are going to integrate GNSS function. It also provides different option of connecting to an external active GNSS antenna depends on different application's requirement.

2 Features

- Tiny size: 14x9.6x1.7mm
- MediaTek high sensitivity solution
- Support 99-channel GNSS
- Fast TTFF at low signal level
- Built-in 12 multi-tone active interference canceller
- Capable of SBAS (WAAS, EGNOS, MSAS, GAGAN)
- Support GPS, GLONASS, GALILEO and QZSS
- low power consumption
- Fast TTFF at low signal level
- ± 1 ns high accuracy time pulse (1PPS)
- Indoor and outdoor multi-path detection and compensation
- SMD type with stamp holes; RoHS compliant
- ISO/TS 16949 quality control
- Up to 10 Hz update rate
- Support RTCM SC-104 Version-2.x(option)

3 Application

- Personal positioning and navigation
- Automotive navigation, model aircraft navigation
- Marine navigation

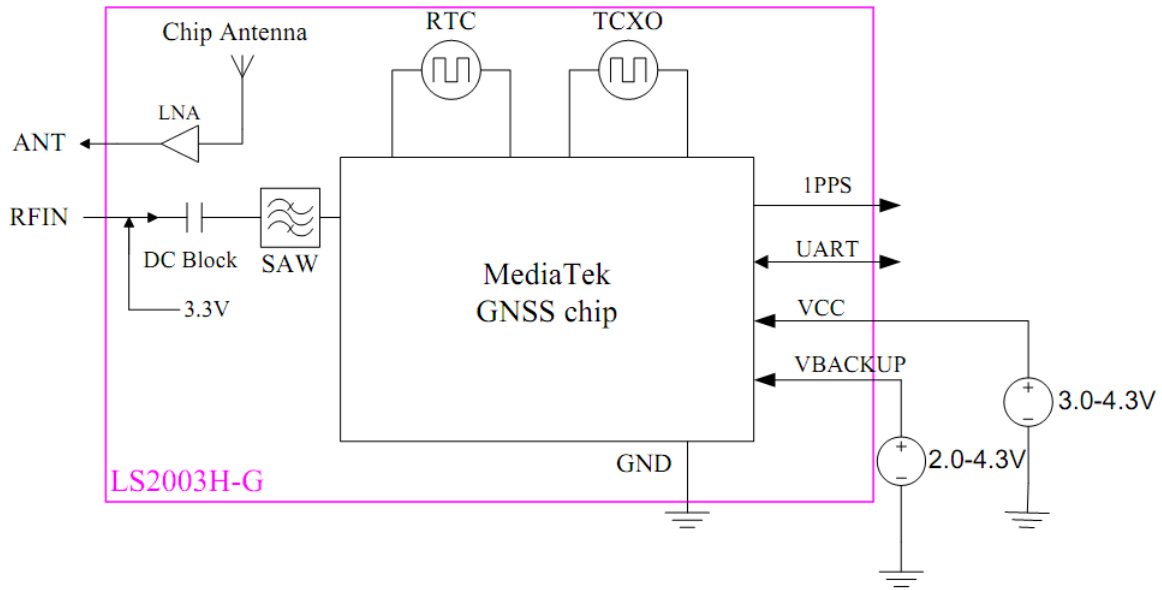

Fig 3-1 System block diagram.

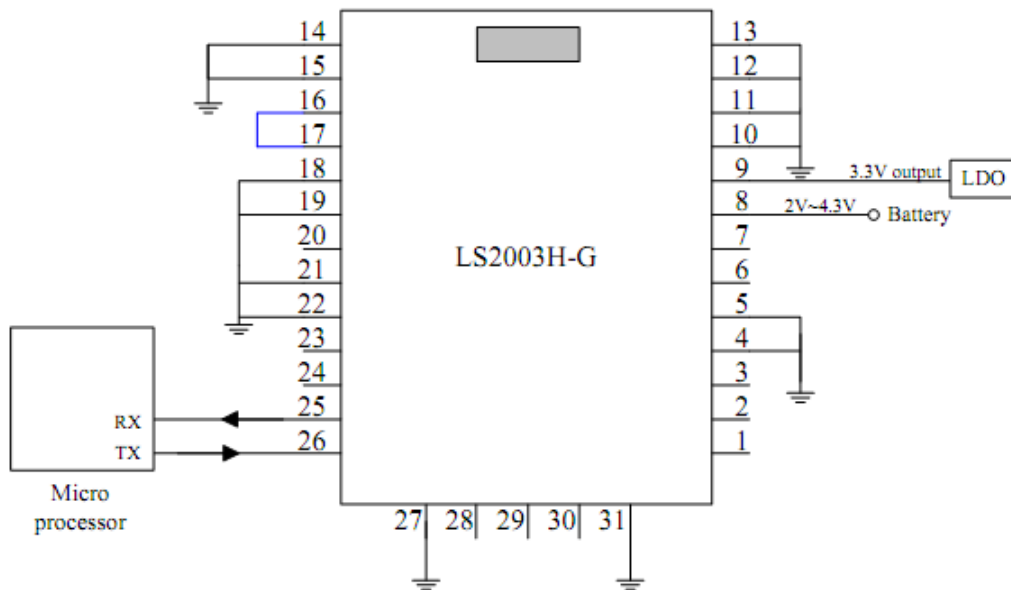

Fig 3-2 Typical application circuit that uses embedded antenna.

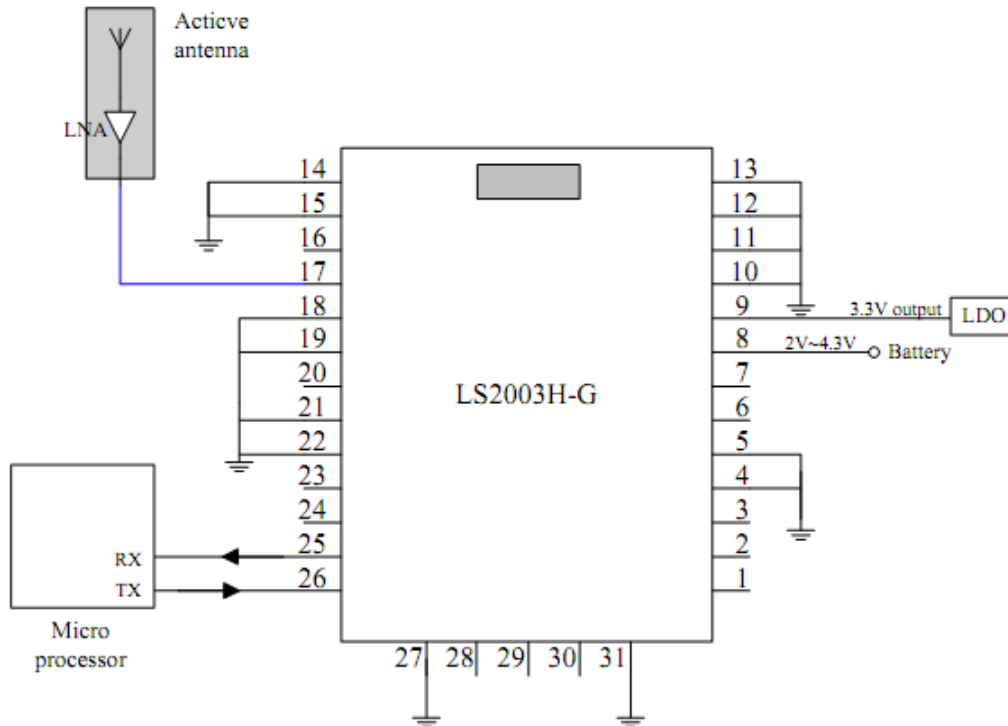

Fig 3-3 Typical application circuit that uses an active antenna.

4 GNSS receiver and antenna

4.1 GNSS receiver

Chip	MediaTek MT3333	
Frequency	GPS, GALILEO, QZSS: L1 1575.42MHz, C/A code GLONASS: L1 1598.0625MHz ~ 1605.375MHz, C/A code	
Channels	Support 99 channels (33 Tracking, 99 Acquisition)	
Update rate	1Hz default, up to 10Hz	
Sensitivity	Tracking	up to -165dBm (with external LNA) ⁽¹⁾
	Cold start	up to -147.5dBm (with external LNA) ⁽¹⁾
Acquisition Time ⁽¹⁾	Hot start (Open Sky)	1s (typical)
	Cold Start (Open Sky)	34s (typical)
Position Accuracy	Autonomous	3m CEP
	SBAS	2.5m (depends on accuracy of correction data).
Max. Altitude	50,000m	
Max. Velocity	< 515 m/s	
Protocol Support	NMEA 0183 ver 4.0	9600 bps, 8 data bits, no parity, 1 stop bits (default) 1Hz: GGA, GSA, GSV, RMC, GLL, VTG
	Real-time Differential Correction	RTCM SC-104 v2.x message types 1,2,3, and 9

Note 1: This value is the sensitivity for RFIN(pin-17).

4.2 GNSS antenna

The antenna type of LS2003H-G is chip antenna. Its performance is greatly affected by many factors, such as the size of PCB ground plane, installation position and its surrounding materials. In order to make it perform well and save you from reinventing the wheel, please consult our FAE before you get started to design.

Antenna type	Chip antenna
Polarization	Linear
Frequency	1575.42MHz ± 1.023MHz ⁽¹⁾ 1598MHz ~ 1606MHz ⁽¹⁾
Peak Gain	-1.04 dBi ⁽¹⁾

Note 1: This value is measured with our evaluation board

5 Pin assignment and descriptions

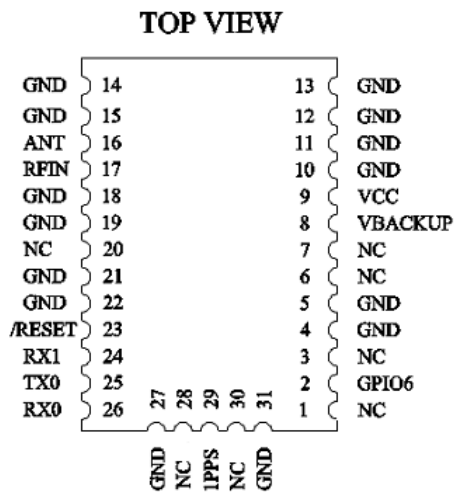

Table 5-1 Pin descriptions

Pin #	Name	Type	Description	Note
1	NC		Not connect	
2	GPIO6	O	Default status indicator. When GNSS position fix is available, it outputs 50ms high per second, otherwise it outputs low.	
3	NC		Not connect	
4	GND	P	Ground	
5	GND	P	Ground	
6	NC		Not connect	
7	NC		Not connect	
8	VBACKUP	P	Backup battery supply voltage. This pin is optional. This pin is optional.	1

9	VCC	P	DC supply voltage	
10	GND	P	Ground	
11	GND	P	Ground	
12	GND	P	Ground	
13	GND	P	Ground	
14	GND	P	Ground	
15	GND	P	Ground	
16	ANT	O	Embedded Antenna Output (50 ohm)	
17	RFIN	I/O	GNSS RF signal input and output voltage for active antenna.	2
18	GND	P	Ground	
19	GND	P	Ground	
20	NC		Not connect	
21	GND	P	Ground	
22	GND	P	Ground	
23	/RESET	I	Manual reset input pin. Active at “L” input. Internal pulled up via a resistor. If /RESET pin is not necessary, open this node.	
24	RX1	I	Serial Data Input for DGPS RTCM Data Streaming	
25	TX0	O	Serial output for channel 0 (Default NMEA)	
26	RX0	I	Serial input for channel 0 (Default NMEA)	
27	GND	P	Ground	
28	NC		Not connect	
29	1PPS	O	Time pulse (1PPS, default 100 ms pulse/sec when 3D fix is available)	
30	NC		Not connect	
31	GND	P	Ground	

<Note>

1. The module doesn't have hot start when this pin and VCC pin are not applied.
2. The bias voltage of RFIN comes from VCC. RFIN does not have short circuit protection.

6 DC & Temperature characteristics

6.1 Absolute maximum ratings

Parameter	Symbol	Ratings	Units
Input Voltage	VCC	4.3	V
Input Backup Battery Voltage	V_BCKP	4.3	V
Operating Temperature Range	Topr	-40 ~ 85	°C
Storage Temperature Range	Tstg	-40 ~ 85	°C

6.2 DC Electrical characteristics

Parameter	Symbol	Conditions	Min.	Typ.	Max.	Units
Input Voltage	VCC		3.0	3.3	4.3	V
Input Backup Battery Voltage	V_BCKP		2.0		4.3	V
Supply Current	Iss	VCC = 3.3V, w/o active antenna,			120 ⁽¹⁾	mA
		Peak		30		mA
		Acquisition		28 ⁽²⁾		mA
		Tracking				uA
Standby			556		uA	
Backup Battery Current	Ibat	VCC = 0V		10		uA
High Level Input Voltage	V _{IH}		2.0		3.6	V
Low Level Input Voltage	V _{IL}		-0.3		0.8	V
High Level Input Current	I _{IH}	no pull-up or down	-1		1	uA
Low Level Input Current	I _{IL}	no pull-up or down	-1		1	uA
High Level Output Voltage	V _{OH}		2.4		3.3	V
Low Level Output Voltage	V _{OL}				0.4	V
High Level Output Current	I _{OH}			2		mA
Low Level Output Current	I _{OL}			2		mA
Minimum Pulse Width	T _{MPW}	For /Reset pin	1			mS

<Note>

1. This happens when downloading AGPS data to LS2003H-G.
2. Measured when position fix (1Hz) is available, input voltage is 3.3V and the function of self-generated ephemeris prediction is inactive.

6.3 Temperature characteristics

Parameter	Symbol	Min.	Typ.	Max.	Units
Operating Temperature	Topr	-40	-	85	°C
Storage Temperature	Tstg	-40	25	85	°C

7 Mechanical specification

7.1 Outline dimensions

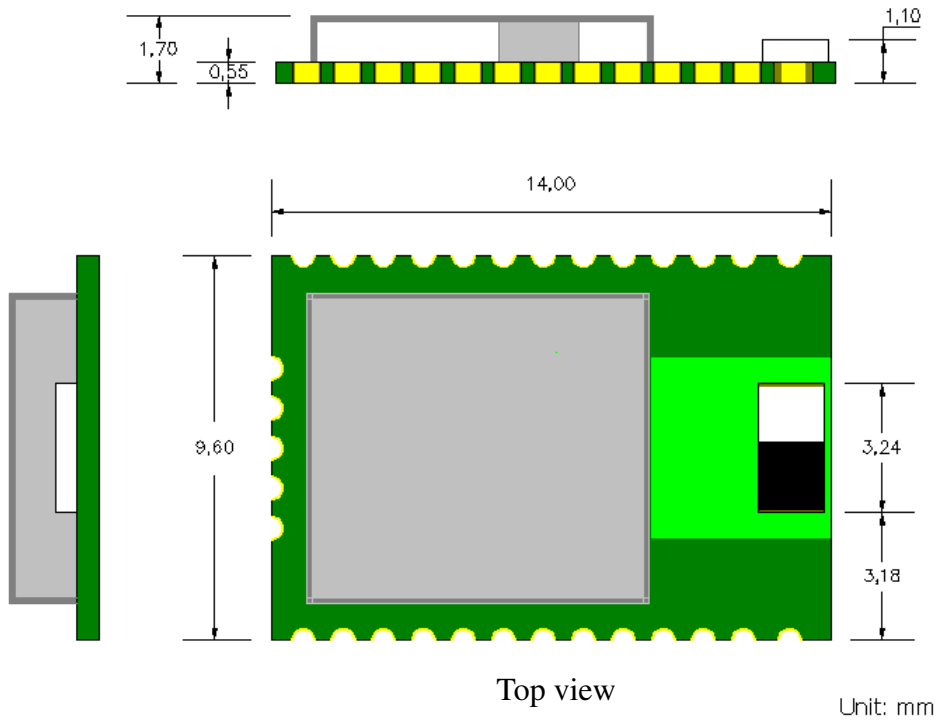

Top view

Unit: mm

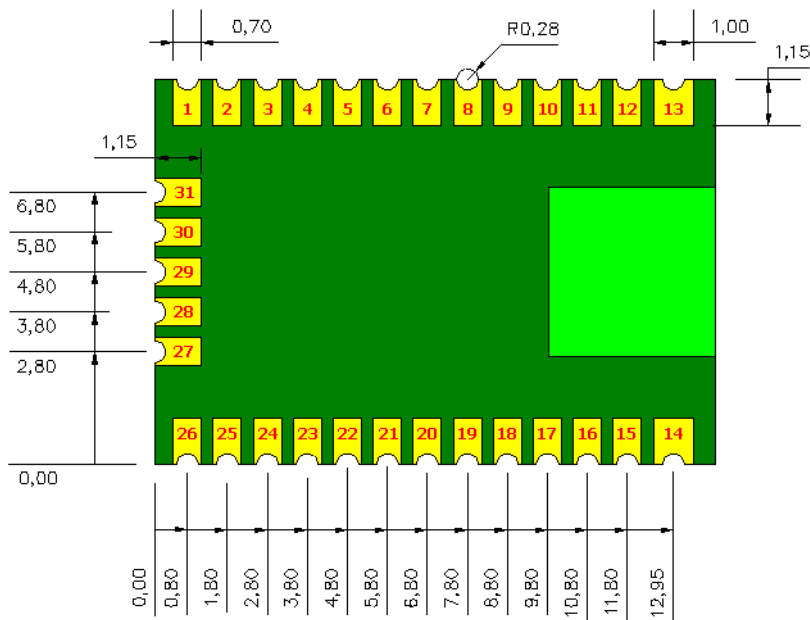

Bottom view

Unit: mm

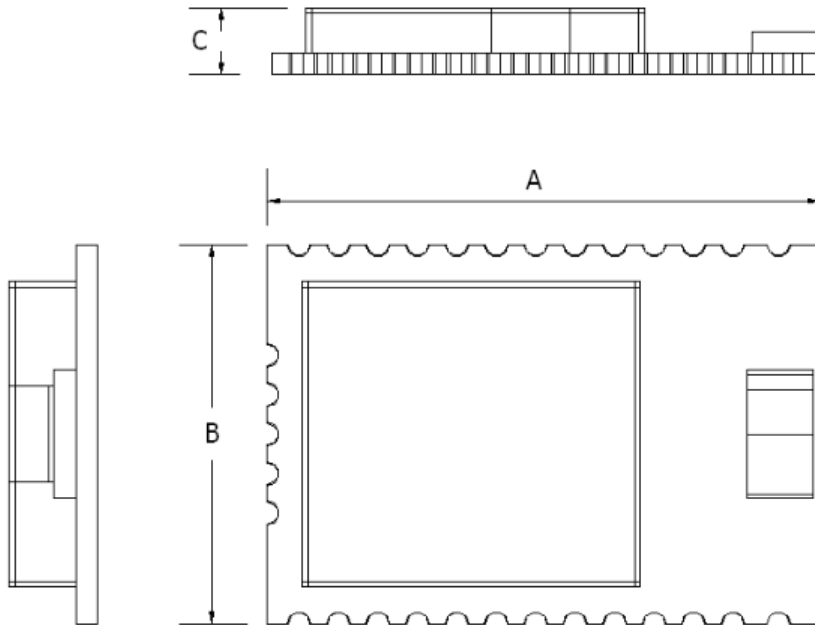

Symbol	Min. (mm)	Typ. (mm)	Max. (mm)
A	14.0	14.0	14.35
B	9.5	9.6	9.7
C	1.55	1.7	1.85

7.2 Recommended land pattern dimensions

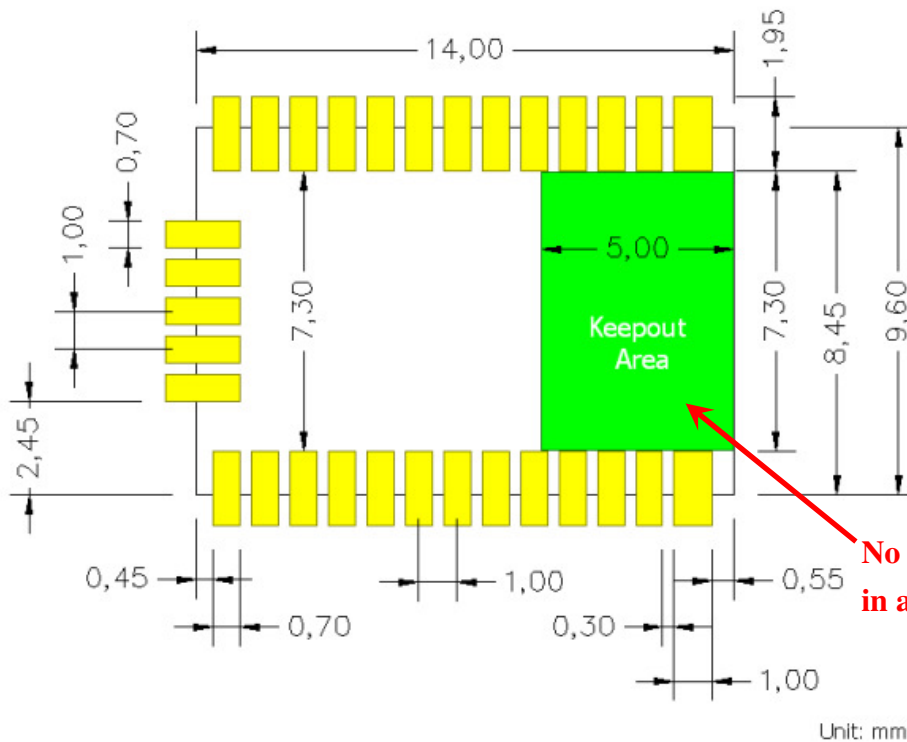

**No copper and traces
in all PCB layers.**

8 Software interface

8.1 NMEA output message

Table 8.1-1 NMEA output message

NMEA record	Description
GGA	Global positioning system fixed data
GLL	Geographic position - latitude/longitude
GSA	GNSS DOP and active satellites
GSV	GNSS satellites in view
RMC	Recommended minimum specific GNSS data
VTG	Course over ground and ground speed

● GGA--- Global Positioning System Fixed Data

Table 8.1-2 contains the values for the following example:

\$GNGGA,053740.000,2503.6319,N,12136.0099,E,1,08,1.1,63.8,M,15.2,M,,*7A

Table 8.1-2 GGA Data Format

Name	Example	Units	Description
Message ID	\$GNGGA		GGA protocol header, GN for GPS+GLONASS, GP for GPS only, GL for GLONASS only
UTC Time	053740.000		hhmmss.sss
Latitude	2503.6319		ddmm.mmmm
N/S indicator	N		N=north or S=south
Longitude	12136.0099		dddmm.mmmm
E/W Indicator	E		E=east or W=west
Position Fix Indicator	1		See Table 8.1-3 (2: DGPS(RTCM) or SBAS)
Satellites Used	08		Range 0 to 33
HDOP	1.1		Horizontal Dilution of Precision
MSL Altitude	63.8	meters	
Units	M	meters	
Geoid Separation	15.2	meters	
Units	M	meters	
Age of Diff. Corr.	0000	second	Null fields when DGPS is not used
Diff. Ref. Station ID	0000		
Checksum	*7A		
<CR> <LF>			End of message termination

Table 8.1-3 Position Fix Indicators

Value	Description
0	Fix not available or invalid
1	GPS SPS Mode, fix valid
2	Differential GPS, SPS Mode, fix valid
3-5	Not supported
6	Dead Reckoning Mode, fix valid

● GLL--- Geographic Position – Latitude/Longitude

Table 8.1-4 contains the values for the following example:

\$GNGLL,2503.7150,N,12138.7463,E,081419.000,A,A*4A

Table 8.1-4 GLL Data Format

Name	Example	Units	Description
Message ID	\$GNGLL		GLL protocol header, GN means GPS+GLONASS, GP means GPS only GL means GLONASS only
Latitude	2503.7150		ddmm.mmmm
N/S indicator	N		N=north or S=south
Longitude	12138.7463		dddmm.mmmm
E/W indicator	E		E=east or W=west
UTC Time	081419.000		hhmmss.sss
Status	A		A=data valid or V=data not valid
Mode	A		A=autonomous, D=DGPS, E=DR, N=Data not valid, R=Coarse Position, S=Simulator
Checksum	*4A		
<CR> <LF>			End of message termination

● GSA---GNSS DOP and Active Satellites

Table 8.1-5 contains the values for the following example:

\$GPGSA,A,3,23,21,16,19,09,27,31,,,,,1.10,0.78,0.78*01

\$GLGSA,A,3,88,87,65,84,71,,,,,1.10,0.78,0.78*18

Table 8.1-5 GSA Data Format

Name	Example	Units	Description
Message ID	\$GPGSA		GSA protocol header, GP means GPS & GL means GLONASS
Mode 1	A		See Table 8.1-6
Mode 2	3		See Table 8.1-7
ID of satellite used	23		Sv on Channel 1

ID of satellite used	21		Sv on Channel 2
....		
ID of satellite used			Sv on Channel 12
PDOP	1.10		Position Dilution of Precision
HDOP	0.78		Horizontal Dilution of Precision
VDOP	0.78		Vertical Dilution of Precision
Checksum	*01		
<CR> <LF>			End of message termination

Table 8.1-6 Mode 1

Value	Description
M	Manual- forced to operate in 2D or 3D mode
A	Automatic-allowed to automatically switch 2D/3D

Table 8.1-7 Mode 2

Value	Description
1	Fix not available
2	2D
3	3D

● GSV---GNSS Satellites in View

Table 8.1-8 contains the values for the following example:

\$GPGSV,3,1,10,27,85,205,49,42,54,141,41,16,51,356,47,19,49,208,47*72

\$GPGSV,3,2,10,23,46,281,46,31,33,111,45,09,25,308,43,21,12,059,39*75

\$GPGSV,3,3,10,193,,,40,04,,,33*43

\$GLGSV,2,1,06,85,71,078,37,75,43,003,38,86,41,186,43,74,35,076,44*6A

\$GLGSV,2,2,06,84,26,032,30,66,07,306,35*6D

Table 8.1-8 GSV Data Format

Name	Example	Units	Description
Message ID	\$GPGSV		GSV protocol header, GP means GPS, SBAS and QZSS Satellites in view & GL means GLONASS.
Total number of messages ¹	3		Range 1 to 4
Message number ¹	1		Range 1 to 4
Satellites in view	10		
Satellite ID	27		Channel 1 (Range 01 to 196) GPS Satellites ID : 01~32, SBAS Satellites ID : 33~64, GLONASS Satellites ID : 65~96, & QZSS Satellites ID : 193~196
Elevation	85	degrees	Channel 1 (Range 00 to 90)
Azimuth	205	degrees	Channel 1 (Range 000 to 359)

SNR (C/No)	49	dB-Hz	Channel 1 (Range 00 to 99, null when not tracking)
....		
Satellite ID	42		Channel 4 (Range 01 to 196)
Elevation	54	degrees	Channel 4 (Range 00 to 90)
Azimuth	141	degrees	Channel 4 (Range 000 to 359)
SNR (C/No)	41	dB-Hz	Channel 4 (Range 00 to 99, null when not tracking)
Checksum	*72		
<CR> <LF>			End of message termination

Note: Depending on the number of satellites tracked multiple messages of GSV data may be required.

● RMC---Recommended Minimum Specific GNSS Data

Table 8.1-9 contains the values for the following example:

\$GNRMC,081419.000,A,2503.7150,N,12138.7463,E,0.01,0.00,160415,,,A*7B

Table 8.1-9 RMC Data Format

Name	Example	Units	Description
Message ID	\$GNRMC		RMC protocol header, GN means GPS+GLONASS GP means GPS only GL means GLONASS only
UTC Time	081419.000		hhmmss.sss
Status	A		A=data valid or V=data not valid
Latitude	2503.7150		ddmm.mmmm
N/S Indicator	N		N=north or S=south
Longitude	12138.7463,		dddmm.mmmm
E/W Indicator	E		E=east or W=west
Speed over ground	0.01	knots	True
Course over ground	0.00	degrees	
Date	160415		ddmmyy
Magnetic variation		degrees	(Not shown)
Variation sense			E=east or W=west (Not shown)
Mode	A		A=autonomous, D=DGPS, E=DR, N=Data not valid, R=Coarse Position, S=Simulator
Checksum	*7B		
<CR> <LF>			End of message termination

● VTG---Course Over Ground and Ground Speed

Table 8.1-10 contains the values for the following example:

\$GPVTG,79.65,T,,M,2.69,N,5.0,K,A*38

Table 8.1-10 VTG Data Format

Name	Example	Units	Description
Message ID	\$GPVTG		VTG protocol header, GN means GPS+GLONASS GP means GPS only GL means GLONASS only
Course over ground	79.65	degrees	Measured heading
Reference	T		True
Course over ground		degrees	Measured heading (Not shown)
Reference	M		Magnetic (Not shown)
Speed over ground	2.69	knots	Measured speed
Units	N		Knots
Speed over ground	5.0	km/hr	Measured speed
Units	K		Kilometer per hour
Mode	A		A=autonomous, D=DGPS, E=DR, N=Data not valid, R=Coarse Position, S=Simulator
Checksum	*38		
<CR> <LF>			End of message termination

8.2 Proprietary NMEA input/output message

Please refer to MTK proprietary message.

8.3 Examples to configure the power mode of GNSS module

The GNSS module supports different power modes that user can configure by issuing software commands.

8.3.1 Standby mode

User can issue software command to make GNSS module go into standby mode that consumes less than 200uA current. GNSS module will be awaked when receiving any byte. The following flow chart is an example to make GNSS module go into standby mode and then wake up.

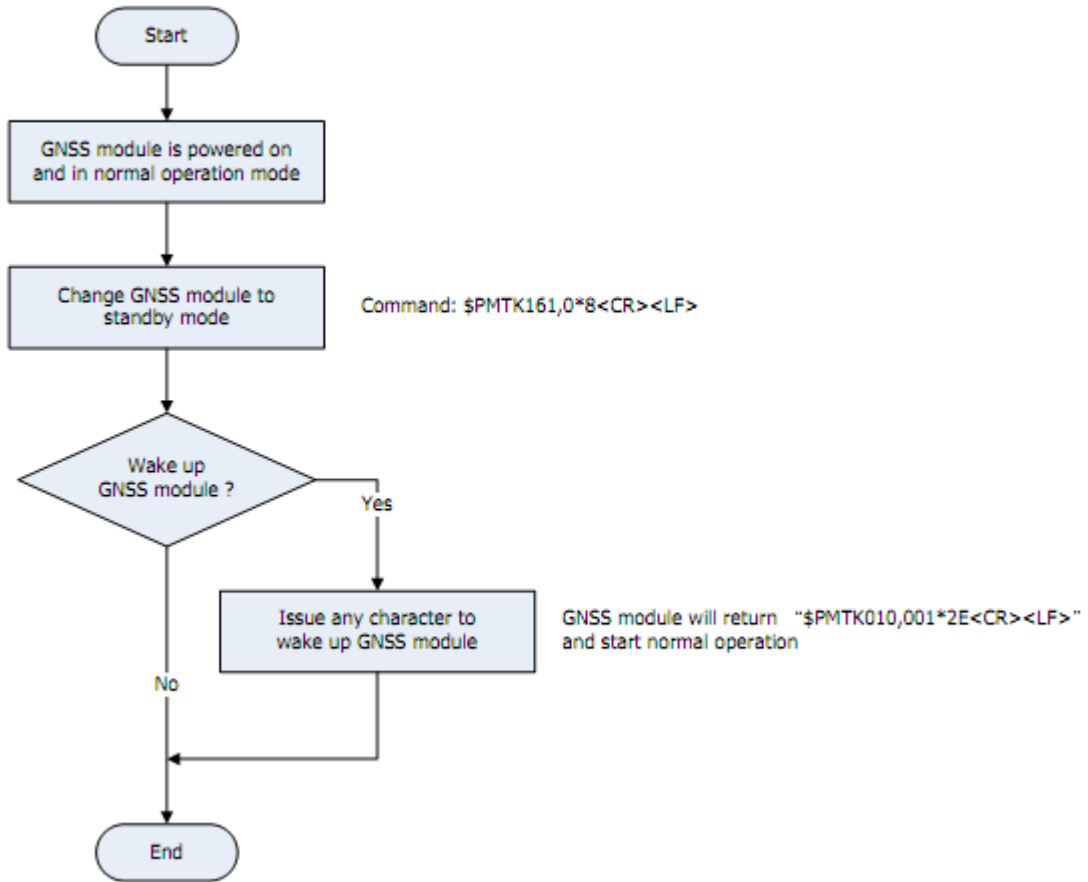

8.3.2 Periodic mode

When GNSS module is commanded to periodic mode, it will be in operation and standby periodically. Its status of power consumption is as below chart.

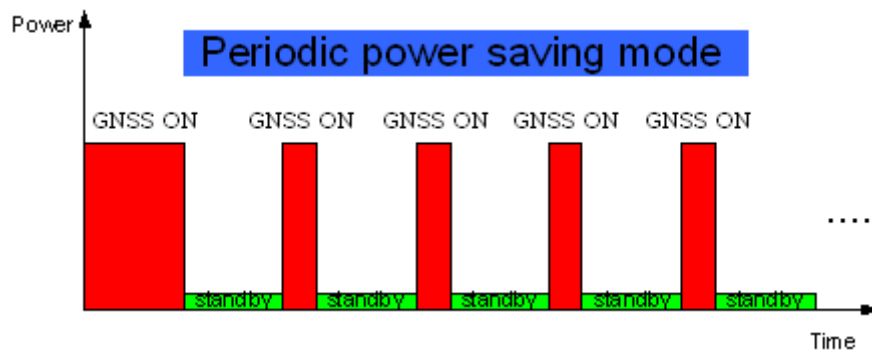

The following flow chart is an example to make GNSS module go into periodic mode and then back to normal operation mode.

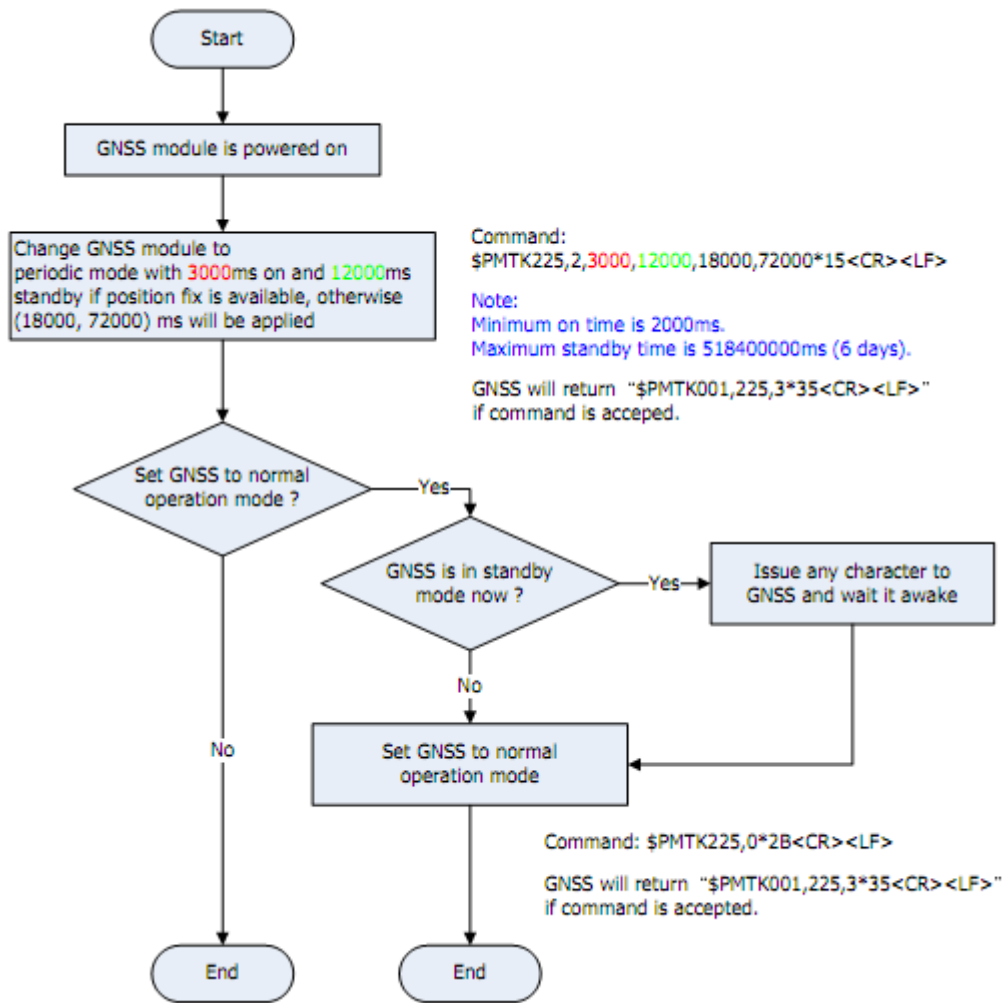

8.3.3 AlwaysLocate™ mode

AlwaysLocate™ is an intelligent controller of periodic mode. Depending on the environment and motion conditions, GNSS module can adaptively adjust working/standby time to achieve balance of positioning accuracy and power consumption. In this mode, the host CPU does not need to control GNSS module until the host CPU needs the GNSS position data. The following flow chart is an example to make GNSS module go into AlwaysLocate™ mode and then back to normal operation mode.

Note: AlwaysLocate™ is a trade mark of MTK.

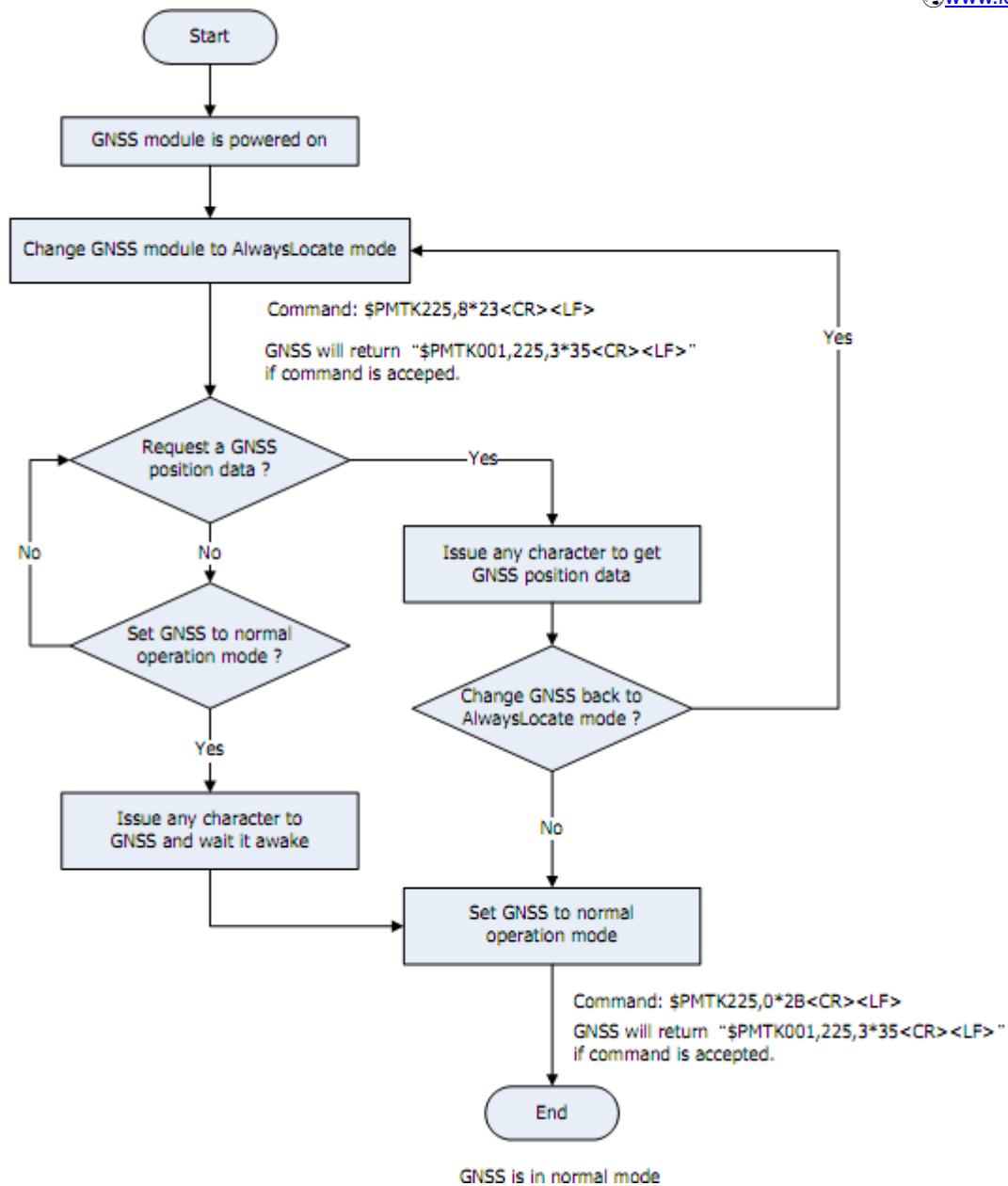

8.4 Data logger

The GNSS module has internal flash memory for logging GNSS data. The configurations include time interval, distance, speed, logging mode, and ... etc. For more information, please contact our FAE.

8.5 Examples to configure the update rate of GNSS module

The GNSS module supports up to 10Hz update rate that user can configure by issuing software commands. Note that the configurations by software commands are stored in the battery-backed SRAM that is powered through VBACKUP pin. Once it drains out, the default/factory settings will be applied.

Due to the transmitting capacity per second of the current baud rate, GNSS module has to

be changed to higher baud rate for high update rate of position fix. The user can use the following software commands to change baud rate.

Baud rate	Software command
Factory default	\$PMTK251,0*28<CR><LF>
4800	\$PMTK251,4800*14<CR><LF>
9600	\$PMTK251,9600*17<CR><LF>
19200	\$PMTK251,19200*22<CR><LF>
38400	\$PMTK251,38400*27<CR><LF>
57600	\$PMTK251,57600*2C<CR><LF>
115200	\$PMTK251,115200*1F<CR><LF>

Note: <CR> means Carriage Return, i.e. 0x0D in hexadecimal. <LF> means Line Feed, i.e. 0x0A in hexadecimal.

If the user does not want to change baud rate, you can reduce the output NMEA sentences by the following software commands.

NMEA sentence	Software command
Factory default	\$PMTK314,-1*04<CR><LF>
Only GLL at 1Hz	\$PMTK314,1,0,0,0,0,0,0,0,0,0,0,0,0,0,0*29<CR><LF>
Only RMC at 1Hz	\$PMTK314,0,1,0,0,0,0,0,0,0,0,0,0,0,0,0*29<CR><LF>
Only VTG at 1Hz	\$PMTK314,0,0,1,0,0,0,0,0,0,0,0,0,0,0,0*29<CR><LF>
Only GGA at 1Hz	\$PMTK314,0,0,0,1,0,0,0,0,0,0,0,0,0,0,0*29<CR><LF>
Only GSA at 1Hz	\$PMTK314,0,0,0,0,1,0,0,0,0,0,0,0,0,0,0*29<CR><LF>
Only GSV at 1Hz	\$PMTK314,0,0,0,0,0,1,0,0,0,0,0,0,0,0,0*29<CR><LF>
Only ZDA at 1Hz	\$PMTK314,0,0,0,0,0,0,0,0,0,0,0,0,0,0,1,0*29<CR><LF>
RMC, GGA, GSA at 1Hz and GSV at 0.2Hz	\$PMTK314,0,1,0,1,1,5,0,0,0,0,0,0,0,0,0*2C<CR><LF>
If the command is correct and executed, GNSS module will output message \$PMTK001,314,3*36<CR><LF>	

After the GNSS module is changed to higher baud rate or reduced NMEA sentence, the user can configure it to high update rate of position fix by the following commands.

Interval of position fix	Software command
Every 100ms (10Hz) ⁽¹⁾	\$PMTK220,100*2F<CR><LF>
Every 200ms (5Hz)	\$PMTK220,200*2C<CR><LF>
Every 500ms (2Hz)	\$PMTK220,500*2B<CR><LF>
Every 1000ms (1Hz)	\$PMTK220,1000*1F<CR><LF>

Every 2000ms (0.5Hz) ⁽²⁾	\$PMTK220,2000*1C<CR><LF>
If the command is correct and executed, GNSS module will output message \$PMTK001,220,3*30<CR><LF>	

Note 1: The minimum interval of position fix is 100ms, i.e. the maximum update rate is 10Hz.

Note 2: The current consumption is the same with the update rate of 1Hz.

8.6 Configure the static navigation parameter

The output position of GNSS module will keep the same and output speed will be zero if the actual speed is below the threshold of the static navigation parameter. This is useful for different applications. For example, the car stopped at a red light will get stationary GNSS position if the threshold is 1.5m/s. It is better to disable this function by setting threshold to 0 for pedestrian navigation.

The format of the software command is as below.

\$PMTK386,speed threshold*checksum<CR><LF>

The unit of speed threshold is meter per second. The range of speed threshold is from 0.1m/s to 2.0m/s. Value 0 is to disable the function.

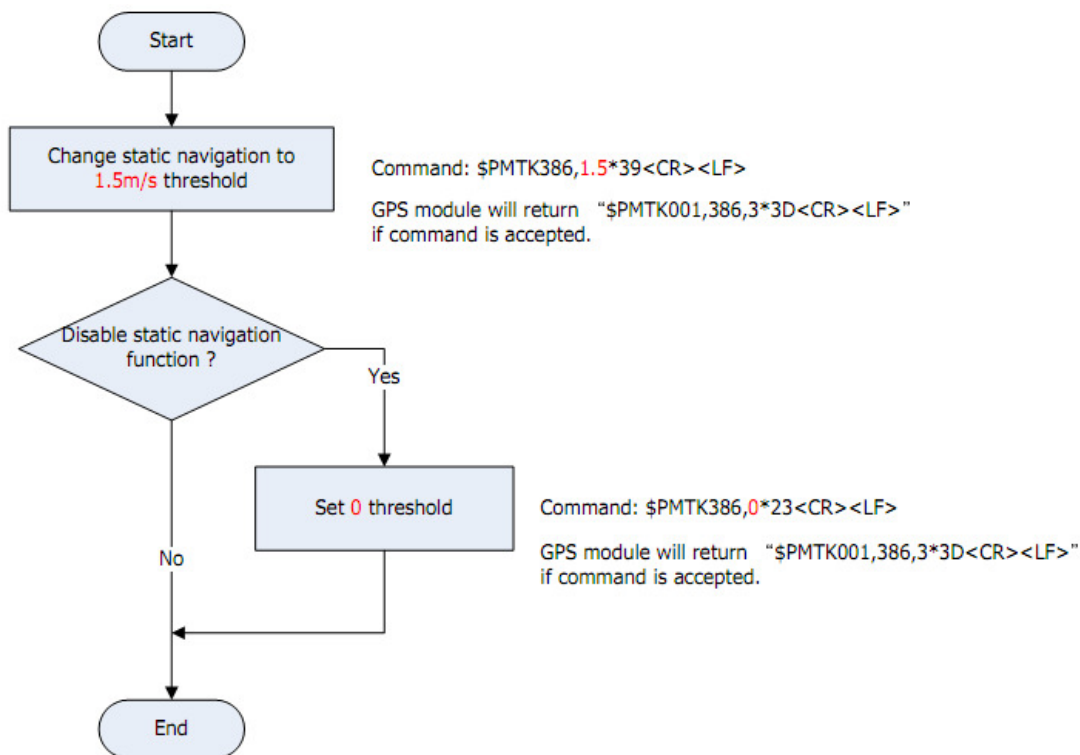

9 Recommended Soldering Temperature Profile

The module belongs to RoHS compliant. The maximum of peak temperature, real on top of PCB, is not over 240 Celsius.

Lead-free Processes

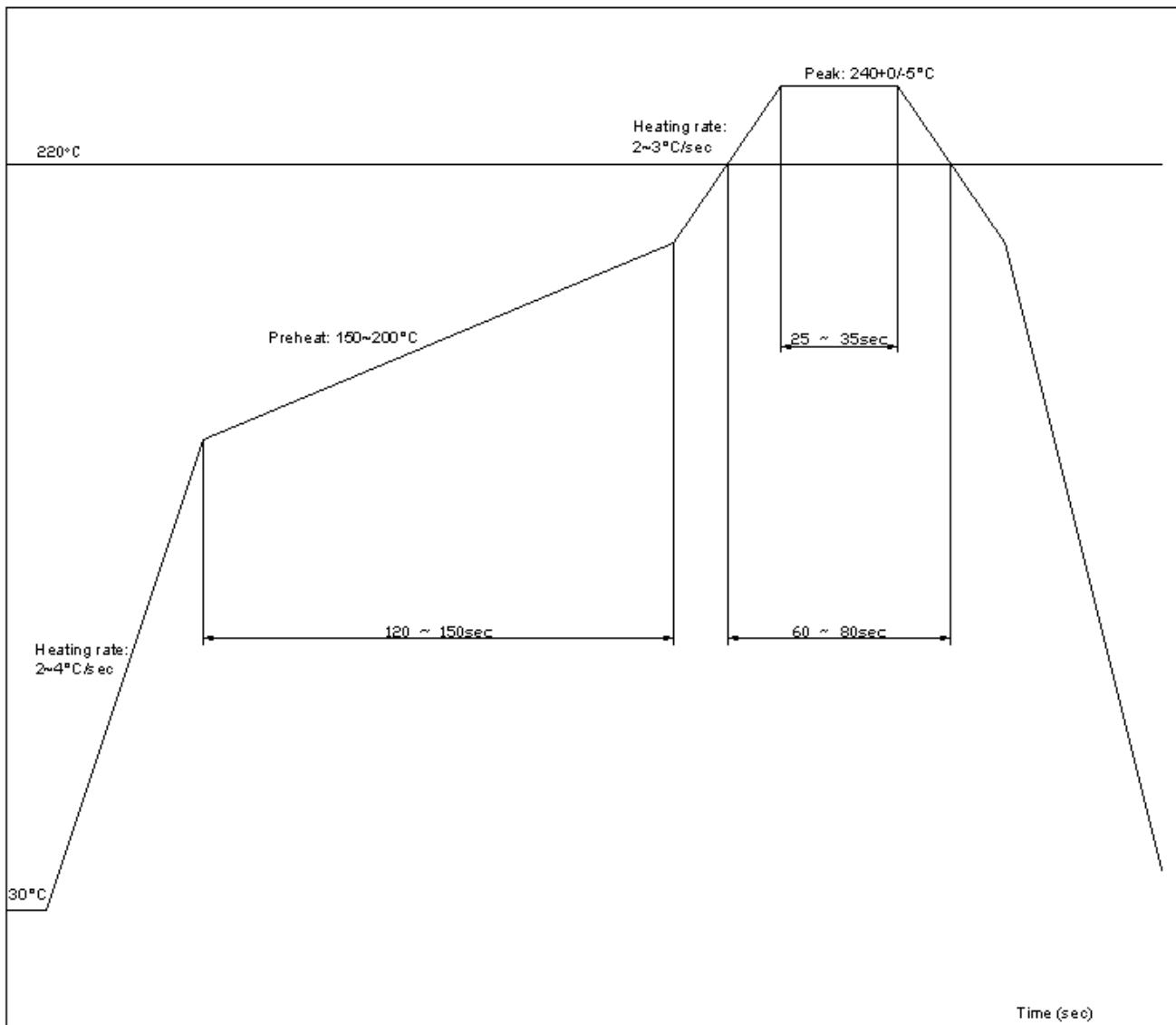

Lead-Free Solder Paste (Sn 96.5-Ag 3.0-Cu 0.5)

Cycle Interval: 300 sec

Note:

The LS2003H-G module should be soldered on the topside in the soldering process to prevent from falling down.

10 Reel Packing information

LS2003H-G modules are deliverable in quantities of 1500 pcs on a reel.

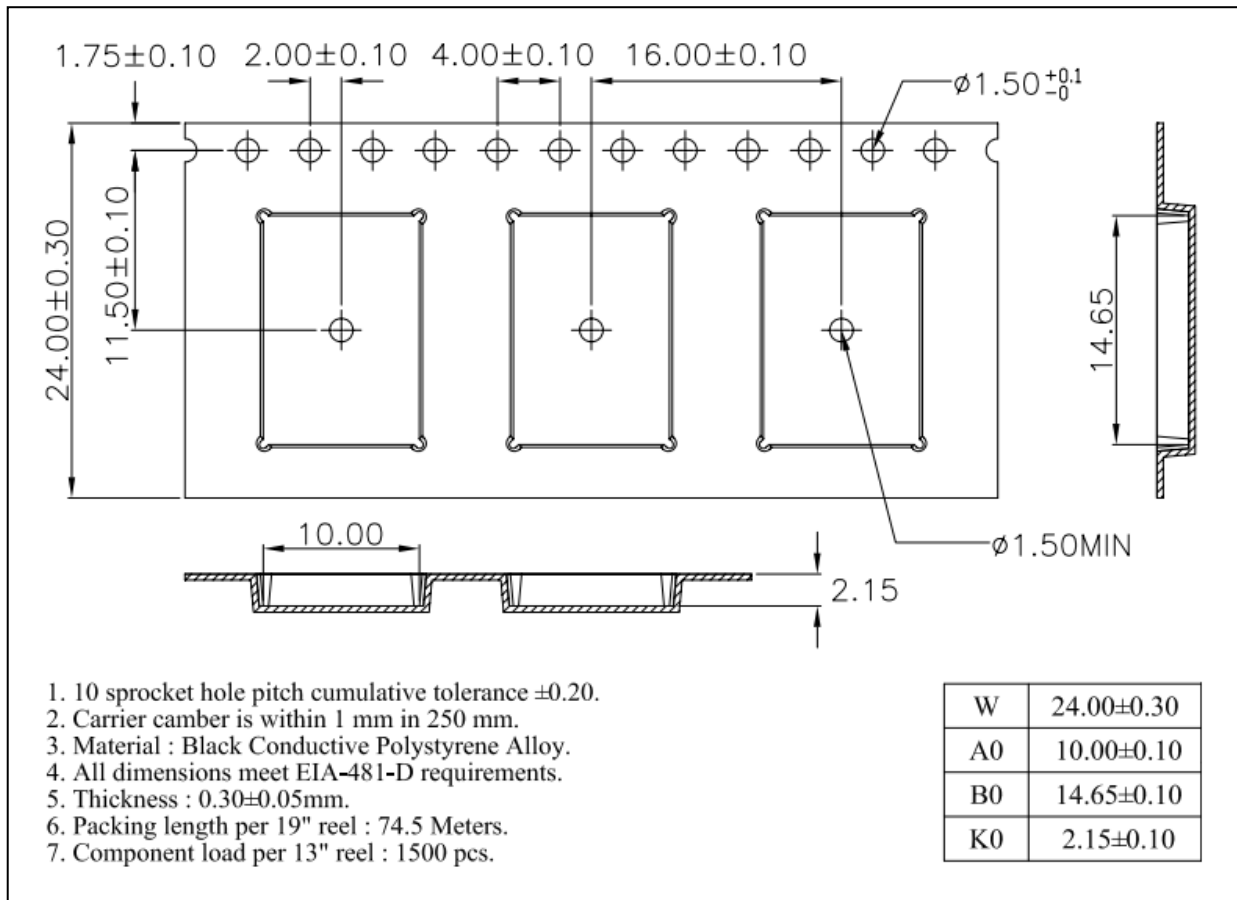

1. 10 sprocket hole pitch cumulative tolerance ± 0.20 .
2. Carrier camber is within 1 mm in 250 mm.
3. Material : Black Conductive Polystyrene Alloy.
4. All dimensions meet EIA-481-D requirements.
5. Thickness : 0.30 ± 0.05 mm.
6. Packing length per 19" reel : 74.5 Meters.
7. Component load per 13" reel : 1500 pcs.

Document change list

Revision 1.0

- Draft release on August 3, 2015.